

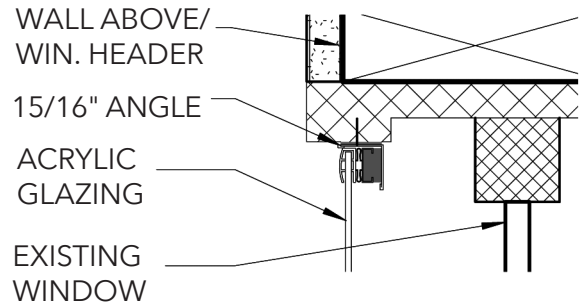

CLIMATE SEAL™

THE WORLD'S BEST THERMAL, ACOUSTIC, PRESERVATION WINDOW INSERTS

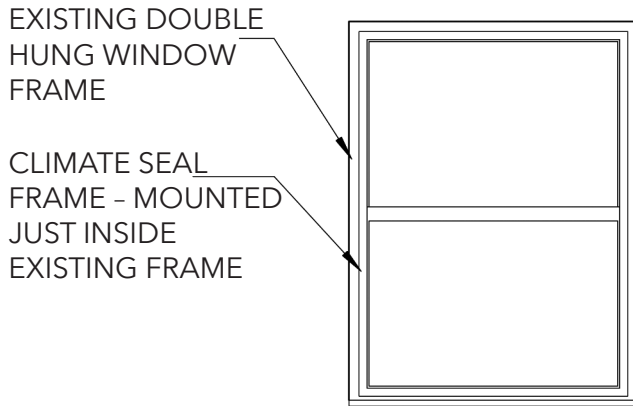

HEAD DETAIL

SCALE: 3" = 1'-0"

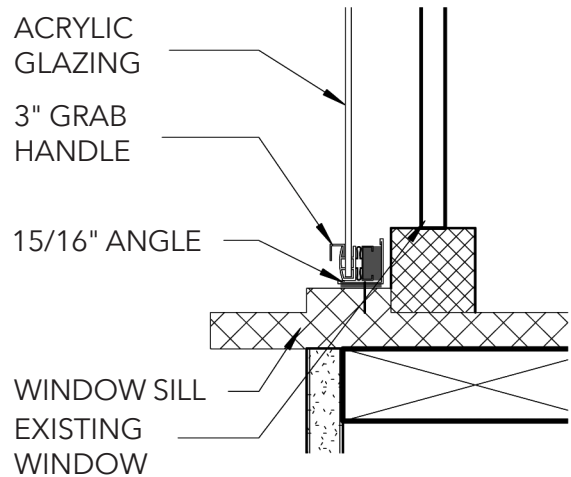
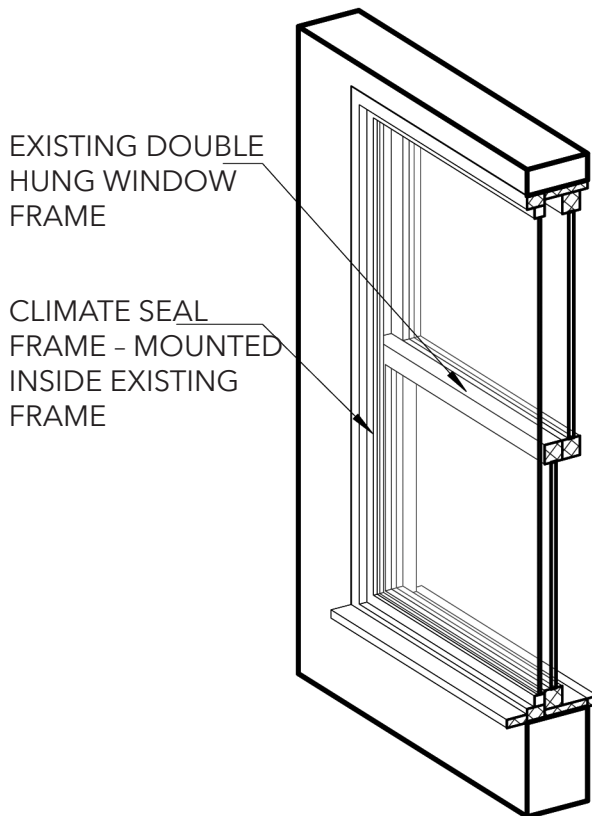

SILL DETAIL

SCALE: 3" = 1'-0"

Climate Seal Win. - Inverted Inside Angle Mount

Scale as indicated

Toll Free: 877.773.7379 • E-mail: sales@climateseal.com • Website: www.climateseal.com

Manufactured by Acoustical Surfaces, Inc., 123 Columbia Court North, Chaska, MN 55318



CLIMATE SEAL™

THE WORLD'S BEST THERMAL, ACOUSTIC, PRESERVATION WINDOW INSERTS

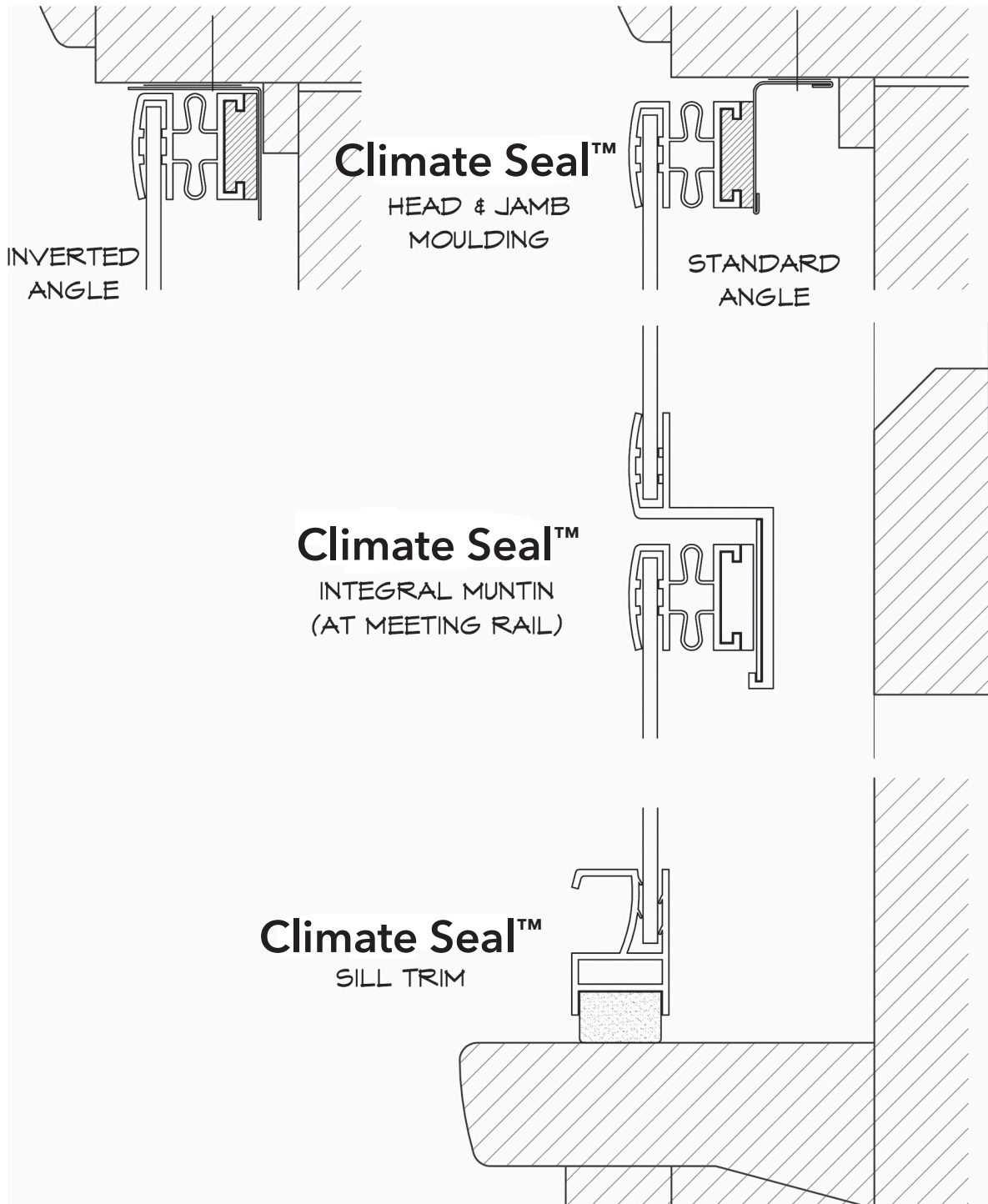

TWO PANEL SYSTEM

Toll Free: 877.773.7379 • E-mail: sales@climateseal.com • Website: www.climateseal.com

Manufactured by Acoustical Surfaces, Inc., 123 Columbia Court North, Chaska, MN 55318



CLIMATE SEAL™

THE WORLD'S BEST THERMAL, ACOUSTIC, PRESERVATION WINDOW INSERTS

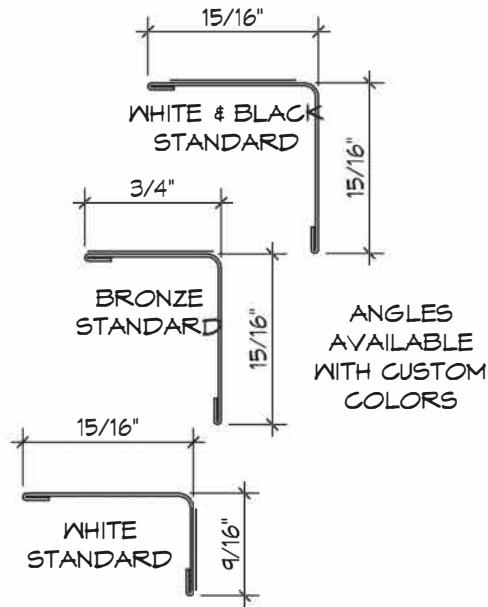

ANGLES AVAILABLE WITH CUSTOM COLORS

STANDARD MOUNTING ANGLES

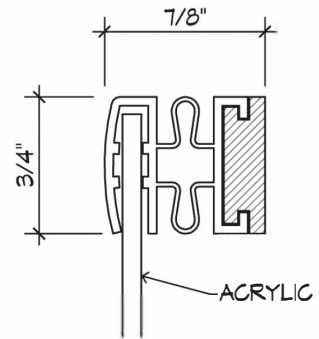
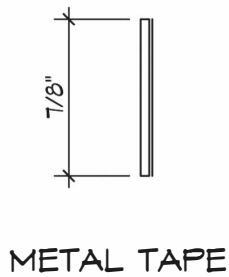
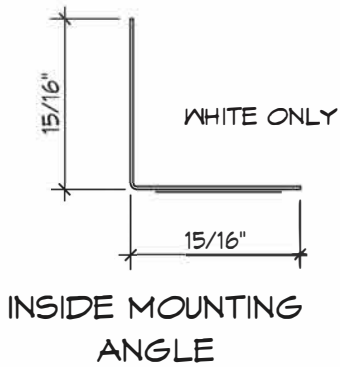

HEAD & JAMB MOULDING

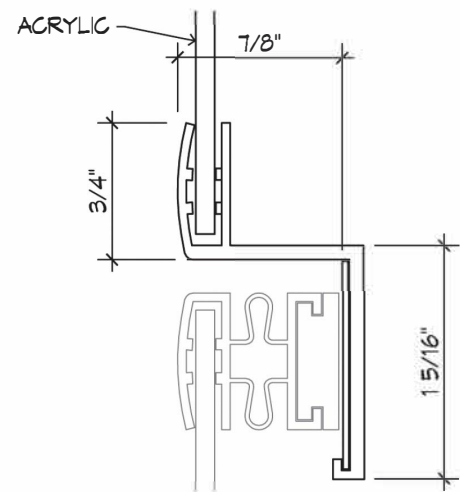

INTEGRAL MUNTIN

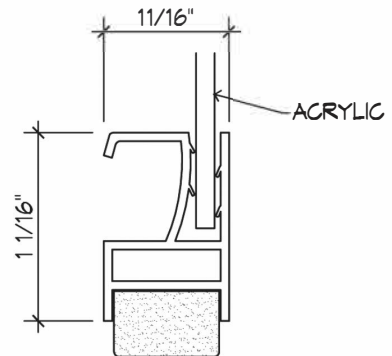

SILL TRIM

Toll Free: 877.773.7379 • E-mail: sales@climateseal.com • Website: www.climateseal.com

Manufactured by Acoustical Surfaces, Inc., 123 Columbia Court North, Chaska, MN 55318